



Excellence in Monitoring

Ronan Model X96S Series Continuous Level System

For more than 27 years Ronan has provided the process control industry with unsurpassed products in the harshest environments. With a philosophy of designing new products to be backward compatible, our customers have the confidence of an installed base of thousands of systems. A worldwide network of dealers, 24-hr factory certified Field Service Engineers and an experienced staff of Applications Engineers are ready to assist with your measurement needs.

Product Information



Applications

- Solids or Liquid Measurement
- Measurement Not Affected by:
 - Internal Obstructions. i.e. Agitators
 - Extreme Process Temperatures
 - Caustic Processes
 - Violent Product Flow
 - Sterile Process
 - Changing Process
 - Variable Product Flow
- Automatic Compensation for Vapor Density Changes
- Automatic Compensation for Foam or Gasses
- Automatic Compensation for Process Build-Up
- Detectors Contoured to the Shape of Vessels
- Upgrade Utilizing Existing Sources

Features and Benefits

- Single Computer, Compatible with all Ronan Detectors. Easily Expandable to Accurately Measure the Most Complex Processes.
- Solid Crystal or Flexible Scintillating Fill-Fluid
- Excellent Measurement Reliability due to Proprietary Filtering Technology
- Lowest Level Sources on the Market
- Level Detection of Multiple Interfaces
- Automatic Decay Compensation
- Low Maintenance / No Component Wear
- Auto-Calibration



Excellence in Monitoring

The X96S Continuous Level Measurement System is designed to deliver outstanding performance in a wide range of difficult applications and process conditions for both liquids and bulk solids. The system utilizes a single computer compatible with all Ronan detectors, which is easily expandable to accurately measure the most complex processes. These include the most dangerous materials such as caustic, toxic, corrosive, explosive, and carcinogenic irrespective of their viscosity and temperature. The modular design is ideal to upgrade older systems while keeping the existing sources.

Measurement Principle

Each system consists of a gamma source, detector and microprocessor. The gamma source, typically mounted external to the vessel emits energy through the vessel walls collimated in a direction towards the detector mounted on the opposite side of the vessel. The gamma energy reaches the detector when the vessel is empty. As the process level rises in the vessel, the gamma energy reaching the detector will decrease in an inversely proportional relationship to the level. The detector measures the level of energy and sends a proportional signal to the microprocessor. The X96 microprocessor linearizes, filters, and correlates this signal to a level measurement.

The entire system is mounted external to the vessel and can be easily installed and maintained while the process is running...without expensive down time, vessel modifications or chance of accidental release.

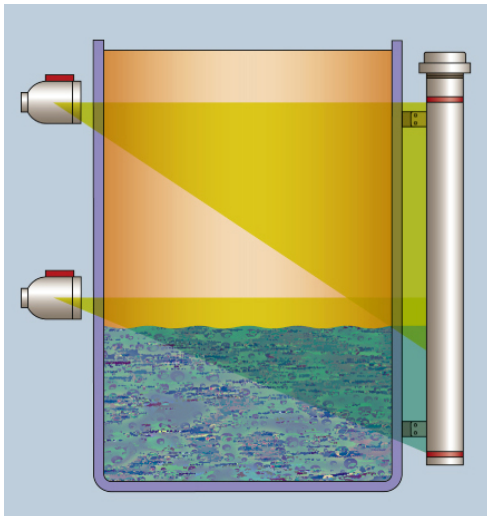

Sources and Detector Mounted External to Vessel

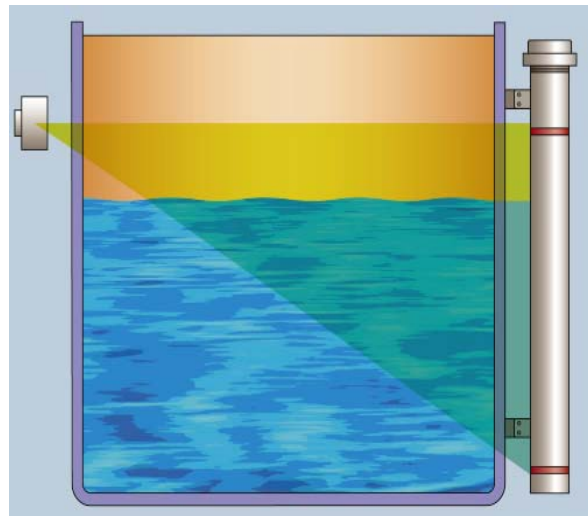

Low Level Source and Detector Mounted External to Vessel



Excellence in Monitoring

X96S Continuous Level System

Source Holders

Ronan pioneered the development of ultra-low level sources to greatly improve safety, and eliminate the requirement for surveys, wipe tests, inspections and much of the documentation. They are so safe the NRC permits their removal and installation without a licensed person being present, translating into significant cost savings for the user.

The RLL-1 ultra low source utilizes very small quantities of radioactive materials. RLL is a Ronan Engineering term that stands for "Radiation Low Level." RLL technology utilizes up to a total of 0.9 mCi (0.033 GBq) of cesium source. In comparison, some conventional density gamma gauges use source sizes with a hundred times more activity to make the same measurement. Because of these very low-levels of activity, and their simplicity of design, Ronan systems are the safest gamma gauges on the market. The NRC recognized this in 1999 when Ronan Engineering attained certification for the first RLL source design.

Ronan understands that installation costs of instrumentation is a major factor when choosing a technology or vendor. To minimize the need to make changes to your existing installation, Ronan offers a wide variety of source holder designs. In addition to external sources, we manufacture small physical sizes for those with space constraints and insertion types for existing wells. Whatever the installation requirements, Ronan can work with you to install the safest source and source holder for the application.



**RLL-1 Low level
Source Holder**



**SA-4, SA-10, SA-15
Insertion Source Holders**



SA-1 Source Holder



Excellence in Monitoring

X96S Microprocessor

The X96S Process Measurement Computers are the most advanced, featuring the fastest processors in the radiometric level gage industry. The modular design allows for low-cost expansion of outputs and measurement variables. Calibration and configuration is in a simplified format and can be achieved locally through push buttons on an liquid crystal graphic display, or remotely through industry standard protocols. The X96S is compatible with all models of Ronan detectors and can accommodate multiple detector inputs for longer measurements.



Features

- For Use in the Following Measurements:
 - Level
 - Level with Density Compensation
 - Mold Level
 - Density
 - Mass Flow
 - Weight
- System Integration via:
 - HART
 - Foundation Fieldbus
 - PROFIBUS PA
- Local Display Shown in HART Format
- Optional Local and/or Remote Eight Line Display
- Flexible, Modular Design Permits Customization
- Multiple Detector Capability
- State of the Art Dynamic Filtering
- Isolated Digital and Analog I/O, Software Settable
- NEMA-4, 4X, Enclosure or Rack Mount Chassis



Excellence in Monitoring

Specifications

Performance	
	The X96S Microprocessor is compatible with all Ronan Detector configurations and is interchangeable between Density, Level and Weight applications.
System Accuracy	+/- 1 % span
Outputs	HART® 4-20mA, Foundation Fieldbus™ PROFIBUS PA Up to 4 Form “C” Relay Outputs Up to 4 Isolated Open Collector Outputs Capable of Switching 4.5 to 30 volts
Inputs	Pressure Input: Support for Process Pressure from 0-10 volts, or 4-20 mA Up to 8 Digital Inputs which can be Configured (Individually) as Dry or Live Contacts, Quadrature, Encoders or Pulse Counters Temperature Input: Nickel or Platinum RTD
Diagnostics	On-Board Modular Self-Test Watchdog Timer and Status LEDs
Calibration	Available Through LOI, PC Based Software or Hand Held Communicator / DCS Utilizing HART® , Foundation Fieldbus™ or PROFIBUS PA RS-232/RS-485 Optional
Environmental	
Operating temperature	-10 to +60 C
Electrical	
Power supply	24 VDC @ .035 A
Mechanical	
Construction	Housing - NEMA 4 Standard - Stainless Steel Optional - Explosion Proof Optional
Approvals	
	Complies with Cenelec/Atex CSA Class 1, Div 1 Groups A,B,C,D Nema 4, Nema 4X
Warranty	
	Three Year Limited Warranty



Excellence in Monitoring

Ronan Scintillation FlexDetector™

The patented Flexible detector utilizes a non-hazardous, non-flammable scintillating fill-fluid, which is doubly encapsulated and protected by an outer sheath of armored conduit. This newest flexible design offers unique advantages in reliability and sensitivity while the lightweight construction eliminates the need to employ cranes and rigging for installation. This design is ideal for horizontal or spherical vessels, or parts of the vessels where space is limited.

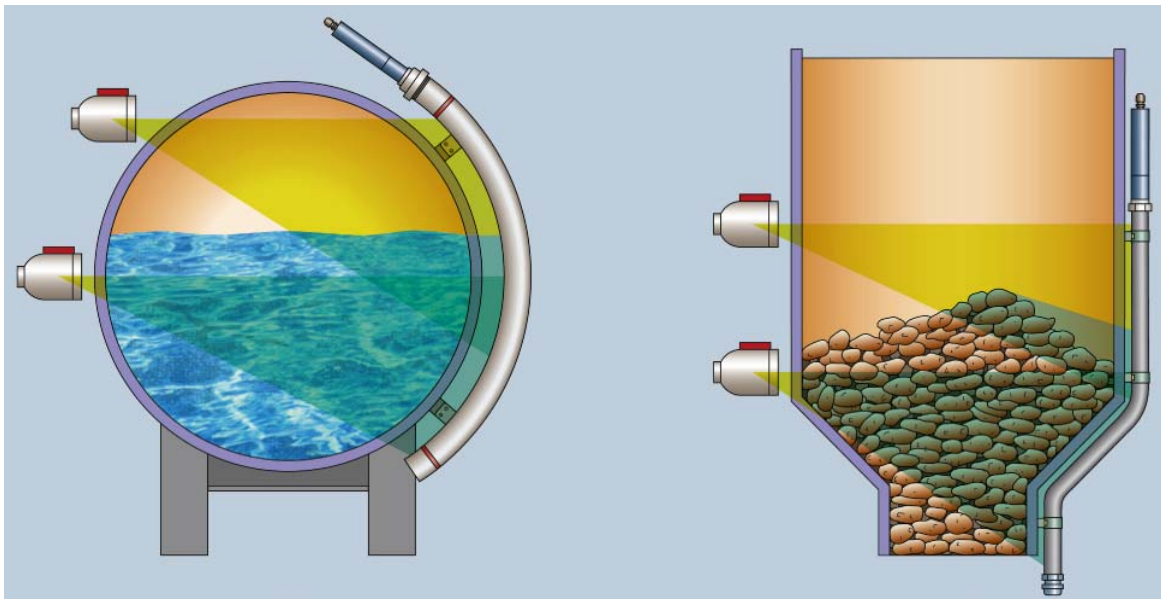

Solid Crystal Detector Pre-Contoured to Shape of Vessel

FlexDetector™ Contoured in the Field to Shape of Vessel



Excellence in Monitoring

The FlexDetector™ is available in lengths up to 23 Feet (7 meters). For longer level measurements, up to four detectors can be summed in a single X96S computer giving an overall continuous level measurement up to 92 feet (28 meters)



FlexDetector™ Can be Shipped Via Regular UPS

Specifications

- High Detector Efficiency, Excellent Sensitivity - Able to Provide Measurements with Lower Intensity Source
- Active Length Up To 23 Feet (7 Meters) - Limits the Need for Multiple Detectors, Reduces Cost
- Spring Tension of PM Tube - Maintains Integrity of the Signal Path Under Vibration and when Detector is Mounted Inverted
- Lightweight and Easy To Install. 1.1 lbs./ft (0.5kg) vs 15 lbs./ft (6.8kg) for Solid Crystal
- Can be Shipped via UPS or Other Carriers...No Need to Ship by Truck - Significant Savings on Freight Cost
- Flexible 12-inch (0.3 Meters) Radius - Fits Around the Contour of Irregular Vessels
- Fill Fluid: Non-Hazardous, Non-Flammable, Non-Toxic
- Improved Linearization Over the Entire Range of Active Length
- Lowest Cost Per Foot
- Ronan Quality Manufacturing - Backed by a Three Year Limited Warranty



Excellence in Monitoring

Performance	
Level Range	The maximum active length of each detector is 23 feet (7 meters). Up to four detectors can be summed in a single electronics, giving a total continuous measurement range of 92 feet (28 meters)
System Accuracy	+/- 1 % span
Environmental	
Operating temperature	-10 to +60 C (Low Temperature and High Temperature Options Available)
Electrical	
Power supply	24 VDC @ .035 A
Mechanical	
Construction	Electronics - Stainless Steel Housing - Aluminum as Standard - 304 Stainless Steel Optional PVC Body - PVC Sheathed Aluminum Armored Flexible Conduit
Fill Fluid	Non-Hazardous, Non-Flammable
Weight	Detector Electronics - 8 lb, Body - 1.1lb per Active Foot (4.6 kg - 0.5Kg)
Approvals	
	Complies with Cenelec/Atex CSA Class 1, Div 1 Groups A,B,C,D Nema 4, Nema 4X
Warranty	
	Three Year Limited Warranty



Excellence in Monitoring

Ronan Rigid Scintillation Detector

Ronan pioneered the use of solid crystal scintillation detectors more than 20 years ago, and now has an installed base in the thousands across a wide variety of applications worldwide. Ronan employs two types of crystals. Scintillating Plastic Crystals for standard applications and Sodium Iodide scintillating crystals for ultra low-level fields. Both types of crystals can be formed to fit the curvature of a vessel...for example, to measure the spherical bottom of a tank.



Features

- High Detector Efficiency
- Detector Lengths up to 15ft Active Length...Longest in Industry
- Only Company to Manufacture Curved Solid Crystals
- Spring Tension of PM Tube. Maintains Integrity of the Signal Path Under Vibration and When Detector is Mounted Inverted
- Lowest Gamma Fields in Industry
- Ronan Quality Manufacturing-Backed by a Three Year Limited Warranty



Excellence in Monitoring

Specifications

Performance	
Level Range	The maximum active length of each detector is 15 feet (4.6 meters). Up to four detectors can be summed in a single electronics, giving a total continuous measurement range of 60 feet (18.4 meters)
System Accuracy	+/- 1 % span
Environmental	
Operating temperature	-10 to +60 C (Low Temperature and High Temperature Options Available)
Electrical	
Power supply	24 VDC @ .035 A
Mechanical	
Construction	Electronics - Stainless Steel Housing - Schedule 40 Carbon Steel, Epoxy Painted - 304 Stainless Steel Optional - PVC Optional
Scintillation Crystal	Plastic or Sodium Iodide
Weight	15 lb/ foot
Approvals	
	Complies with Cenelec/Atex CSA Class 1, Div 1 Groups A,B,C,D Nema 4, Nema 4X
Warranty	
	Three Year Limited Warranty

DATE	SYMBOL	REVISION RECORD	DR	OK
3/7/88	1	GENERAL REVISION	DR	
7/7/89	2	REDRAWN ON CADD	JG	
3/7/90	3	GENERAL REVISION	JG	
2/12/92	4	CHANGED DIMENSION	JG	CC
6/10/96	5	REDRAWN ON AUTOCAD	CMS	
5/23/97	6	ADDED MILLIMETERS, EGR #1733	RMC	
8/6/02	7	ADDED SECOND ASSY DWG: EGR #3226	AVP	
3/5/03	8	ADDED LIFTING EYE	AVP	
1/23/09	9	ADD THIRD TAB, NOTE #2; EGR #4051	AVP	
6/3/11	9	REMOVED J-BOX & NIPPLE, EGN #3109	AVP	

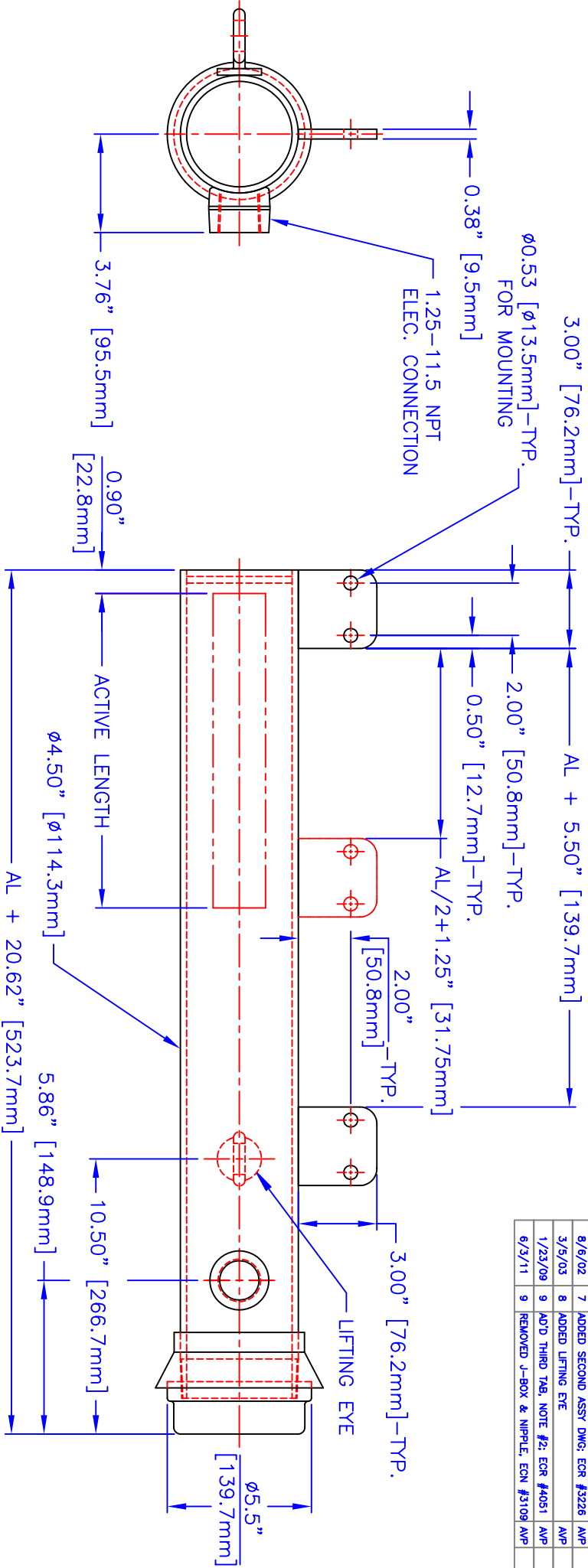

NOTES:

- ESTIMATED WEIGHT:
 - W = 37 + (AL X 1.7) lbs
 - WITH AL IN INCHES
 - W = 16.65 + (AL X .03) kg
 - WITH AL IN MILLIMETERS
- A THIRD TAB IS USED WHEN DETECTOR ACTIVE LENGTH IS >120".

FOR ASSEMBLY SEE DRAWING B-10560-K

ROMAN		MEASUREMENTS DIVISION	
CUSTOMER:	SCALE	DR. BY	CMS
	1:4	APPR. BY	
TITLE OUTLINE:			
3.0" DIA. SCINTILLATION DETECTOR			
DATE	DRAWING NUMBER	REV.	
7/28/87	B-3180-K	10	

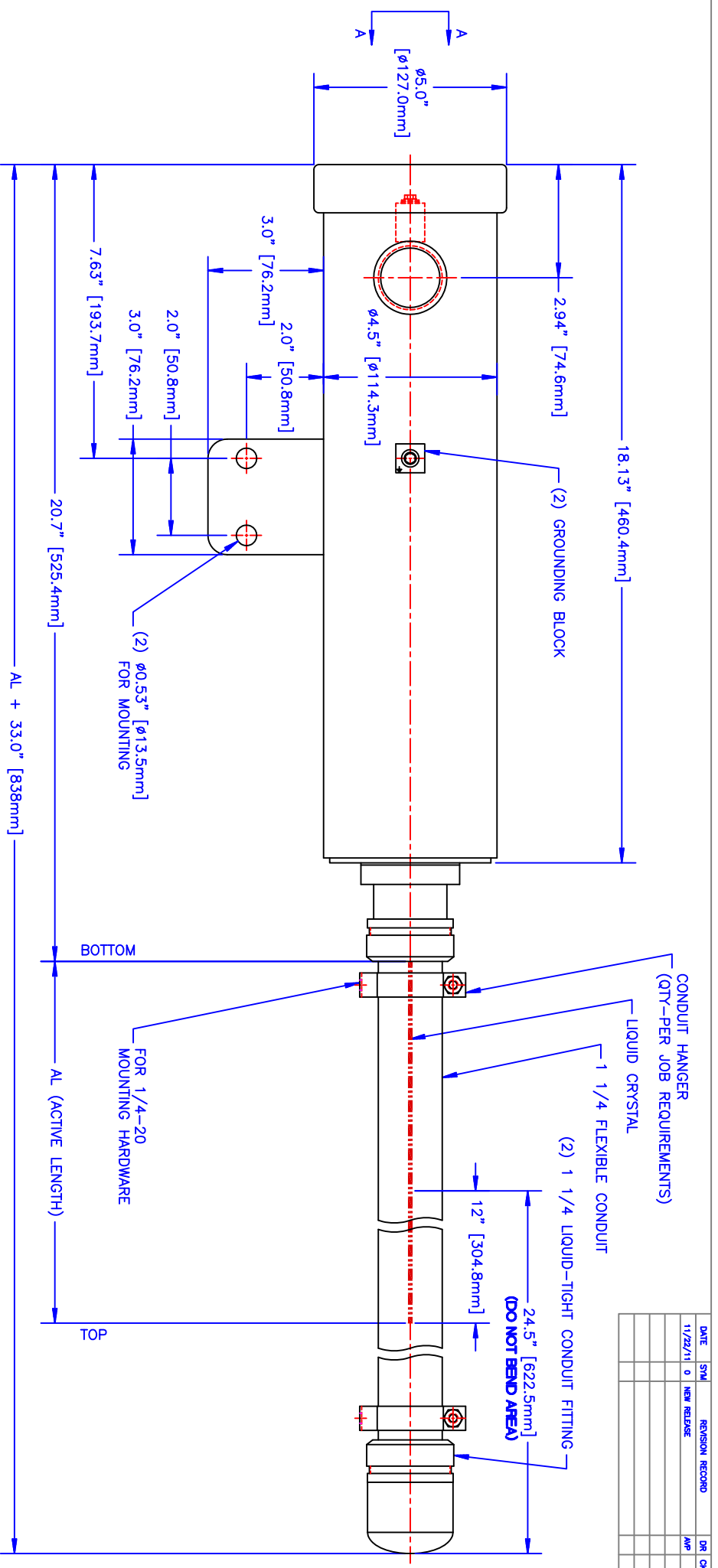

NOTES:

- ESTIMATED WEIGHT:
 - W = 18.2 + (0.34 X AL) lb
 - WITH AL IN FEET.
 - W = 8.7 + (0.0005 X AL) kg
 - WITH AL IN MILLIMETERS.
- MINIMUM BEND RADIUS = 12" [305mm].

1 1/4-1 1/2 NPT
ELECTRICAL CONNECTION

(2) Ø0.53" [13.5mm]
FOR MOUNTING

(2) GROUNDING BLOCK

CONDUIT HANGER
(QTY-PER JOB REQUIREMENTS)

LIQUID CRYSTAL

1 1/4 FLEXIBLE CONDUIT

(2) 1 1/4 LIQUID-TIGHT CONDUIT FITTING
(DO NOT BEND AREA)

FOR 1/4-20
MOUNTING HARDWARE

BOTTOM

TOP

FOR ASSEMBLY SEE DRAWING D-22850-K

DATE	SYM	REVISION RECORD	DR	CK
11/22/11	0	NEW RELEASE	APP	

CUSTOMER:	SCALE: DR. BY/APP
	1:2 APPR. BY
TITLE: OUTLINE: DETECTOR, SCINTILLATION, LIQUID CRYSTAL, FLEXIBLE CONDUIT	
DATE: 11/22/11	DRAWING NUMBER: C-22834-K
	REV: 0